



Fender Mount Installation Considerations Dual Band, VHF/UHF Antennas

(ALL)-DB-VHF/UHF
PATENT PENDING

VERIFY:

1. **Part List:** The system package includes antenna, cable(s), broadcast coupler and connectors if applicable. Use only components supplied with the antenna.
2. **Bandwidth:** VHF/UHF Broadband antennas are 24 MHz wide, within the range of 150-174 MHz, and 34 MHz wide between 406 and 512 MHz unless stated otherwise on label. Extended tuning ranges are available. Be certain that the antenna was tuned to the frequencies required.

INSTALLATION:

Refer to the Antenna Mounting Instructions provided for your specific antenna model.

Note: Be careful not to tear the sheath of cable when pulling through sharp body panels. If a hole appears in the antenna's sheath, cover with several layers a high quality electrical tape.

1. **Grounding:** Fender-mount antennas must be grounded at the point where the antenna passes through the body of the vehicle. The antenna base must be fastened snugly to the fender. (Be careful not to over-tighten) If required, follow the grounding procedure for installation of the grounding kit. Antennas lacking ground will produce high-reflected power.
2. **Interconnect:** Refer to Figure 1 - VHF/UHF Dual Band Assembly Configuration. Do not tape or secure any feedlines to data or vehicle cables during installation.

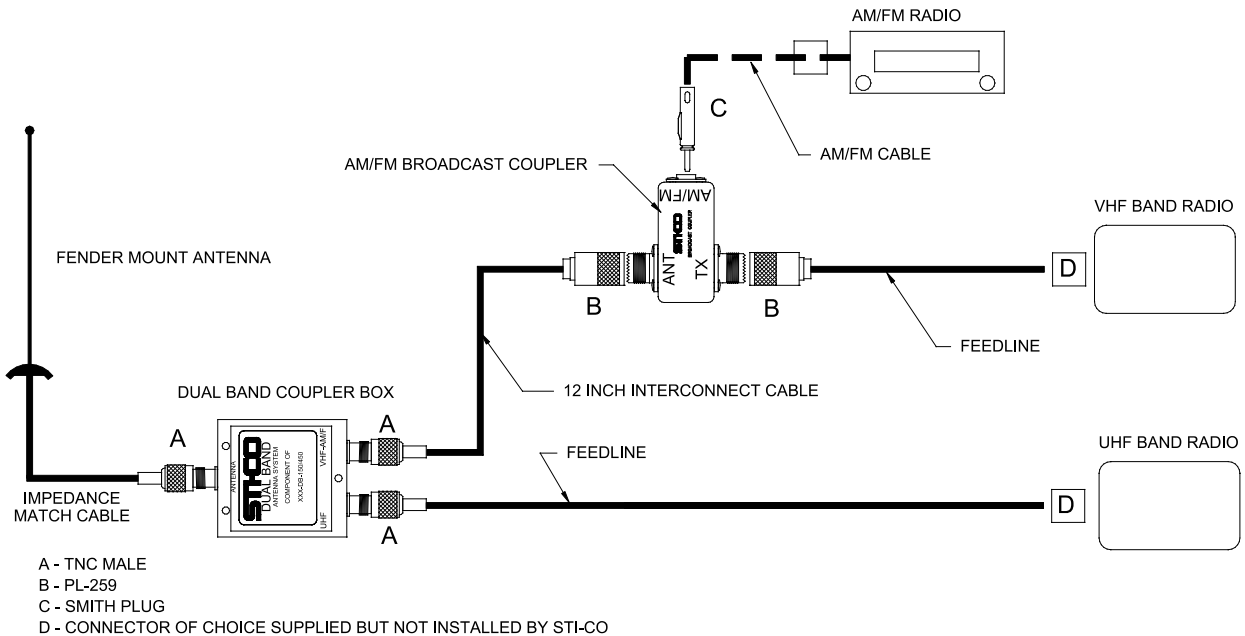
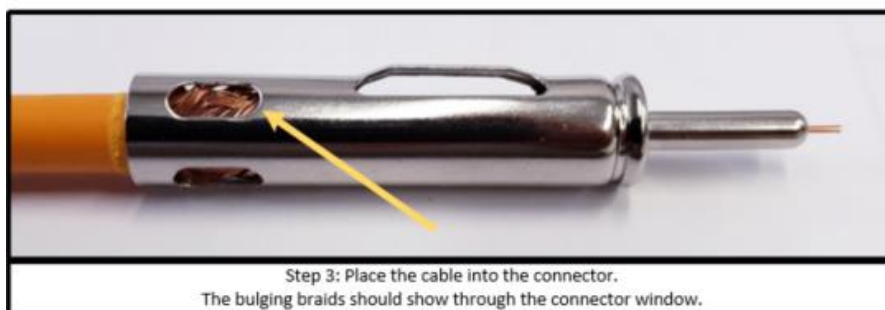
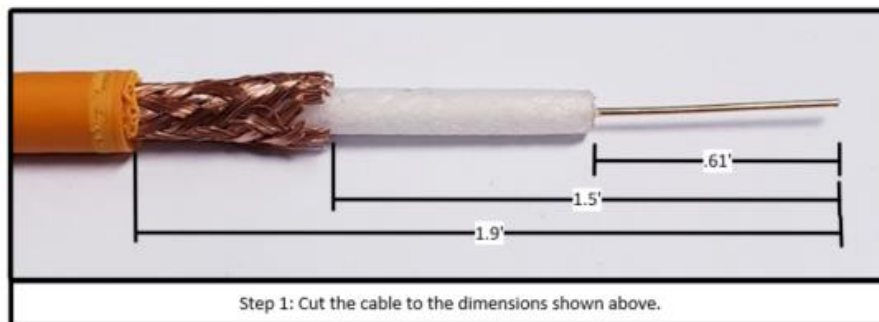

Figure 1 - VHF/UHF Dual Band Configuration



3. **Electromagnetic interference:** Do not coil feedline cable or matching network. If limited space is a concern, fold the cable upon itself rather than coiling.
4. **Moisture Prevention:** Antennas installed on the front fenders should have a drip bend made with the cable to prevent water running down the cable into the connectors. Bending the section of cable coming from the antenna base/ fender into a "U" shape can make a drip bend. Water will drip off rather than flow into the connectors or coupler boxes. Attempts should be made to bring all couplers inside the cabin of the vehicle so they are not exposed to the elements.
5. **Feedline Cable Cutting:** Cut the feedline cable to the appropriate length required to reach the transmitter. **Do not cut the impedance match cable.** Install connector D.
6. **Radio Cable:** The entertainment radio cable may not have the correct connector to tie into the broadcast port; in that case you must install the Smith jack (supplied) onto that cable per instruction below.







Step 6: Bridge the bulging braids to the connector with solder.
Do not solder all four openings, only two opposite windows to reduce risk of damage to the cable. There should be enough solder to hold the braids onto the connector.





TESTING:

Installation testing must take place at the transmitter side of the feedline. Make sure all the doors, the hood, and trunk are closed.

Note: *Some vehicles are sensitive to VHF frequencies. STI-CO suggests that you isolate feedlines and check for unwanted interference with the ignition switch on.*

1. **Reflective Power:** A measurement of reflective power using a wattmeter, you can expect up to 11% reflected power. When results are greater than 11%, recheck grounding.
2. **SWR:** A measurement of SWR (standing wave ratio) will yield better than 2:1. If greater than 2:1, recheck grounding.

CAUTION: *The mast must be removed before entering a car wash.*