



# Superband <sup>®</sup>, VHF Antenna

## RDCA-SB-VHF AND RDCA-SB-VHFL

### VERIFY:

1. **Part List:** The system package includes magnetic base, spring assembly, tunable mast, fiberglass rod, magnetic top bracket, connector tab, matching cable network, feedline, and connectors if applicable. Use only components supplied with the antenna system (Refer to Figure 1-Parts List).
2. **Bandwidth:** VHF Superband <sup>®</sup> antennas are 24 MHz wide. The antenna is designed to operate between 150 MHz to 174 MHz unless otherwise specified. RDCA-SB-VHFL antennas cover 136MHz to 160 MHz.

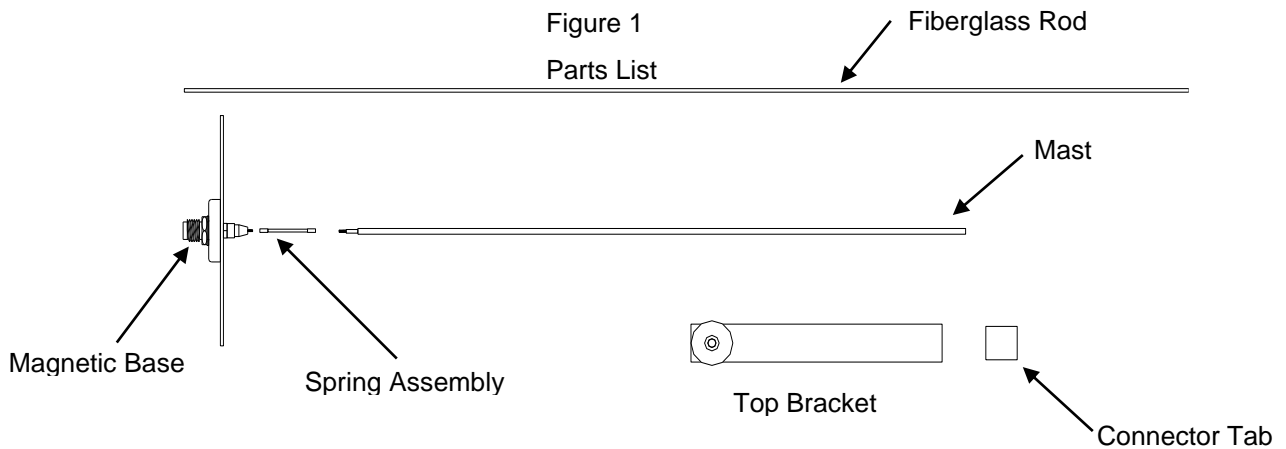

### BASE INSTALLATION:

This antenna is designed with a universal mounting system **HOWEVER** due to the amount of differences between vehicle platforms we can't anticipate all of the challenges an installer may face. A certain amount of modification may be needed based on your particular installation.

The installation begins by locating a point on centerline of the back deck that is clear of any obstructions such as rear brake lights or safety belt restraint latches. The antenna base should be at least 4 to 6 inches from the rear glass. See note A in figure 2 below.

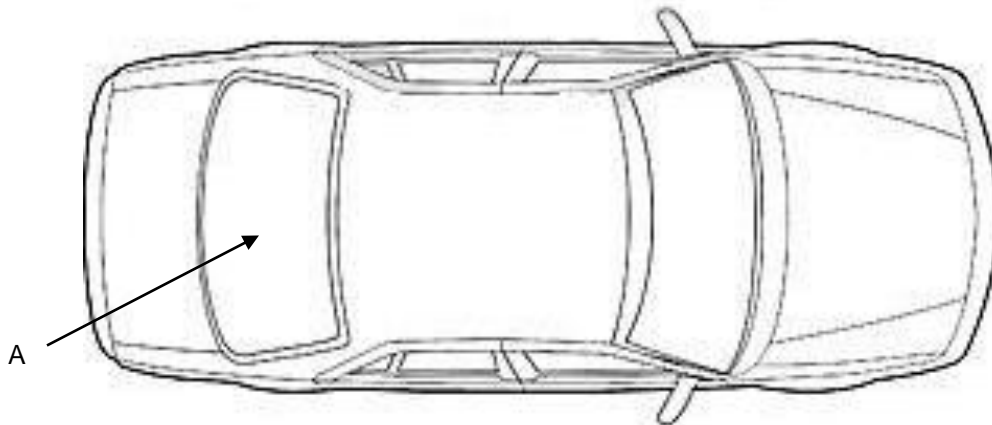

FIGURE 2



1. Drill a 7/16" hole from the underside of the deck through the metal frame as close to the chosen location as possible. Be careful not to go through the insulation in order to better conceal the base of the antenna.

Using a sharp knife cut a small slit or X over the top of the drilled hole to allow the top of the base to protrude.

2. Install the magnetic antenna base from the underside of the deck. See figure 3 below.

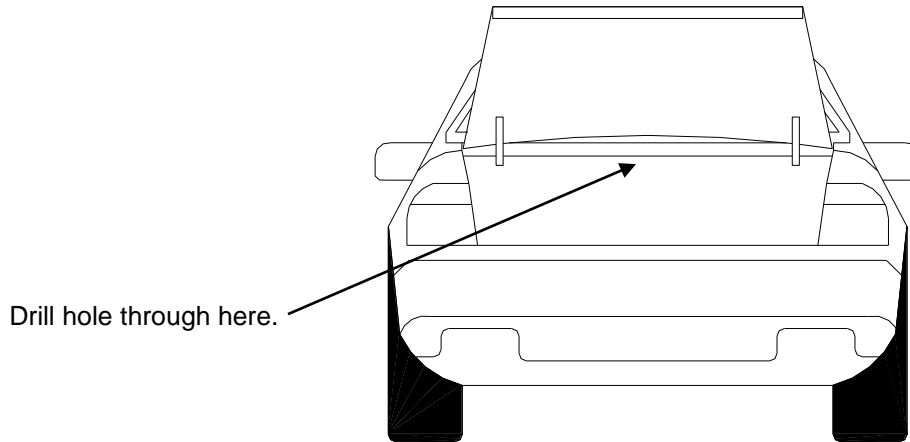

Figure 3

3. The magnet is designed to hold the base in place while 2 sheet metal screws are installed as close to the magnet as possible to secure the assembly to the frame. See figure 4 below.

\* Caution: Cabling must have strain relief support to prevent damage to connector.

Install 2 sheet metal screws  
as close to magnet as  
possible.

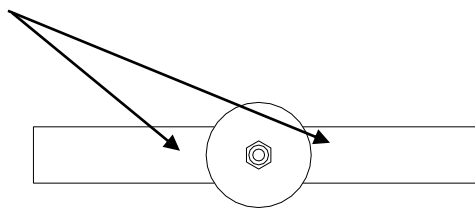

Figure 4

4. From the top of the deck carefully thread the spring assembly onto the protruding base. Screw the tuning mast onto the spring assembly.



**TOP BRACKET INSTALLATION:**

**NOTE** It is very important that the metal portion of the antenna is kept at least 1 inch away from any vehicle chassis ground points including vehicle frame, defogger wires, factory OEM in glass wires, trim screws etc. **NOTE:** Vehicles with aftermarket tint must have non-metallic tint.

5. Install the top bracket by removing any clips or trim along the top edge of the rear glass and carefully pulling down the headliner. Place the magnet on the metal along the vehicle centerline and position the strap so that only a small amount is visible and it aligns with the antenna. The copper strap may be trimmed in length for a better fit.

The connector pad has a setscrew used to secure the fiberglass rod. Make sure the hole with the screw is placed to the side of the strap when attaching. Peel and stick the connector pad onto the exposed strap.

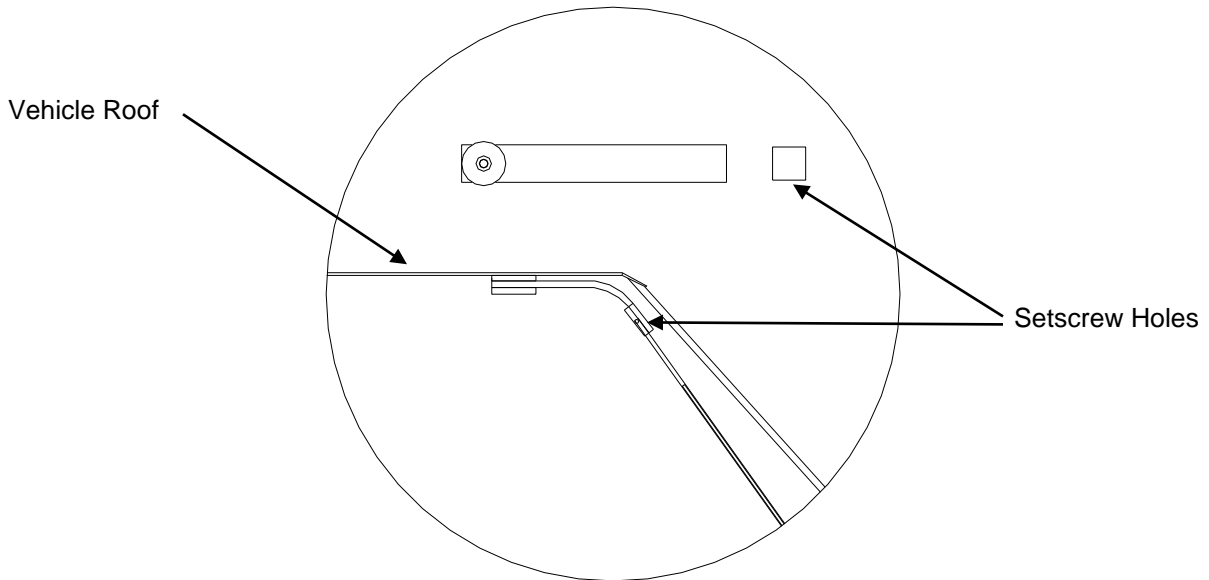

Figure 5

6. Measure the length of fiberglass rod needed by inserting the finished end of the rod into the tuning mast and holding it up to the connector pad. Cut the rod to length. Fiberglass has a tendency to splinter if cut with diagonal cutters. Use a saw or sharp knife to cut across the fibers. Always use the appropriate eye protection and gloves to avoid injury.

Slide the cut rod through the connector pad and into the tuning mast.

Tighten setscrew from the side of the connector pad to secure the rod in place.

Reinstall any trim or screws for the headliner.



## TESTING AND VERIFICATION:

Installation testing, if required, must take place at the transmitter side of the feedline. This will ensure that the cable connectors and cables have the proper continuity. Make sure all doors, hood, and trunk are closed.

***Note:** Some vehicles are sensitive to VHF frequencies. STI-CO suggests that you isolate feedline and check for unwanted interference with the ignition switch on.*

1. **Reflective Power:** A measurement of reflective power using a wattmeter, you can expect up to 11% reflected power. When results are greater than 11%, recheck grounding.
2. **SWR:** A measurement of SWR (standing wave ratio) will yield better than 2:1. If greater than 2:1, recheck grounding.
3. Connect the feedline provided from the antenna base to a wattmeter. Connect from the wattmeter to the transmit radio. Set the radio to a frequency that is closest to the center of the band of operation. Measure the reflected power
4. Check the reflected power above and below the center frequency to verify antenna matching. Remove wattmeter and proceed to the final hook-up.
5. Connect the matching harness from the antenna base to the radio.
6. Installation is now complete.