



NMO Base Preparation Instructions

H-1955

OVERVIEW:

The NMO base comes dis-assembled for High Frequency NMO use (Note detail B). For spring pin type antenna bases, please follow the instructions below:

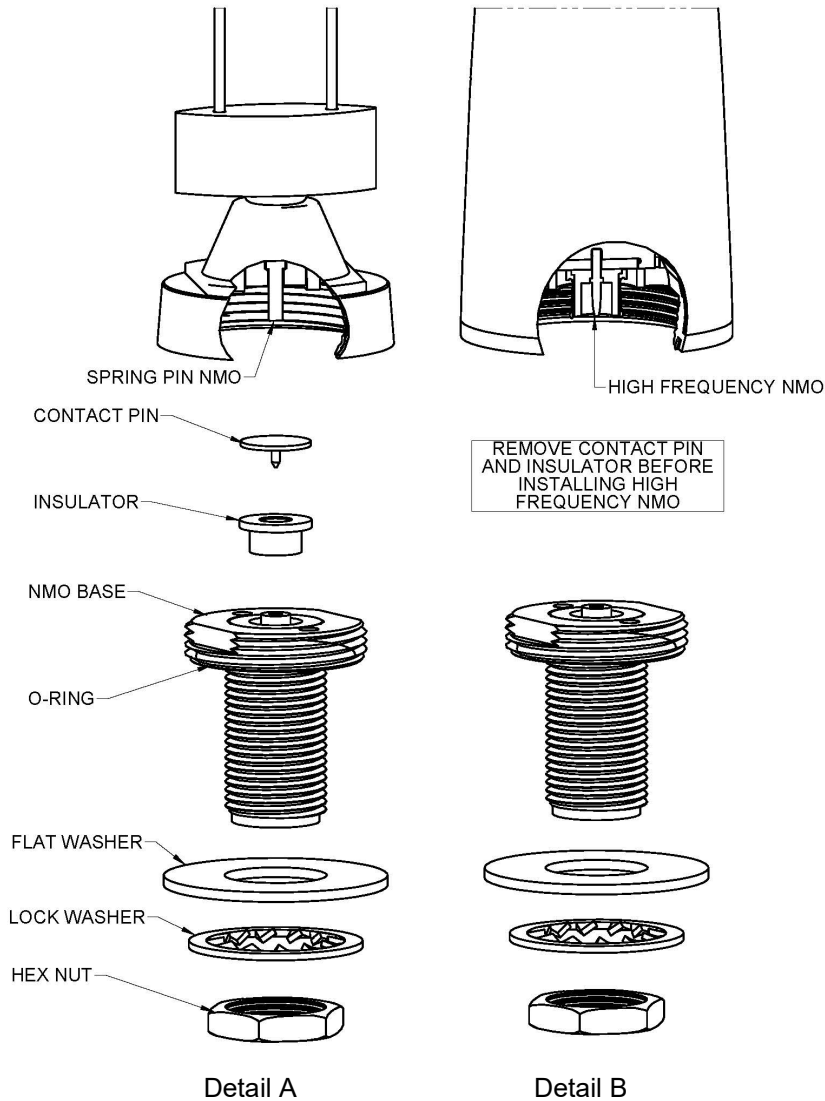

INSTALLATION:

1. For High Frequency antenna base, the center pin and insulator may be discarded.
2. For the Spring Pin style base insert the insulator into the NMO base, next install the center pin fully seating both components
3. The base may now be installed on the vehicle per corresponding instructions